

**Rotisol-France, Inc.**

**ELECTRIC GRANDES FLAMMES  
ROTISSERIES**

Ref.: 950/3 950/5 950/8 1350/3 1350/5 1350/8 1650/8

**USER MANUAL**

## 1 – GENERAL INFORMATION

This equipment is for professional use and should be operated by qualified personnel.

This equipment should be installed according to current regulations and standards, in a well-ventilated location.

We recommend that you use a qualified installer to install the equipment.

The rating plate is located at the back of the unit.

## 2 – START-UP AND OPERATION

In order to avoid grease splashes and for the proper operation of the unit, the glass doors must remain closed during cooking cycles.

- Turn the main switch ON (right hand side - bottom switch)
- Switch ON the heating elements using the knobs on the left 15 minutes prior to cooking.
  - o Position I is LOW
  - o Position II is MEDIUM
  - o Position III is HIGH
- Fill the bottom drip pan with about 1” of water. Make sure you always have water in the drip pan.
- Spit your products and load the unit by inserting the round end of the spit on the left side first and then the hexagonal end on the right (motor side).
- The top switch (right hand side) controls the halogen light.
- The fan indicator light, located at the bottom (right hand side) will be ON for about 10 seconds when the main switch is turned ON. If the light is always ON, the motors are not cooled anymore. If so, please contact your vendor.
- If pressed, the red push button will switch off the entire unit (safety knob).

### 3 – RECOMMENDATIONS

- Always use heat-proof gloves when loading/unloading the unit.
- Make sure the glass doors are fully opened when loading/unloading the unit.
- Perform daily cleaning of the unit with a soft cloth and a strong degreaser (see cleaning instructions).
- Do not let the drip over-flow. Empty it when needed.
- Do not touch the halogen light and do not move the unit when light is ON.

### 4 – COOKING TIPS

- Cooking time for chicken varies between 1 hour – 1 hour 15 minutes (bring the core temperature of the chicken to 165F-185F).
- Cook full power on position III (HIGH)
- After the cooking cycle, the unit can be put on holding mode. Bring the spit all the way forward and switch the heating elements to position I (LOW). Do not forget to keep the spits rotating.
- Use the hooks to adjust the spit. You do not have to open the doors to do so: they fit in the opening between the frame of the rotisserie and glass.

### 5 – CLEANING INSTRUCTIONS

#### 5-1 Daily cleaning

- It is very important to clean the rotisserie on a daily basis. Soak the spits and the drip pan for easier cleaning.
- Clean the rotisserie when it is still warm.
- The inside stainless steel panels as well as the glass doors must be cleaned with a non-abrasive detergent and a soft rag.
- Make sure to clean around the motor shafts by pulling them back and forward.
- ROTISOL recommends HOT N' FOAMY special rotisserie cleaner.
- To empty the drip pan. Lift the back of the pan and pull it forward a few inches. Put a deli pan under (right hand side) and unscrew the drain plug.

### 5-2 MONTHLY

- free the motors of grease deposits by applying a strong degreaser with a brush on the motor shafts. Turn the motors ON for 5 minutes then rinse with a soft sponge.

### 5-3 EVERY 6 MONTHS

- Do a thorough check-up of the rotisserie.

For a better operation, we recommend to establish a maintenance program with an authorized service company (please contact us).

## 6 – EQUIPMENT VERIFICATION

We recommend checking the equipment upon reception. Your rotisserie was packaged with care. If you notice something breakage, please inform your vendor immediately.

**GRANDE FLAMMES ELECTRIC REF: 950/1350 - 3 SPITS**

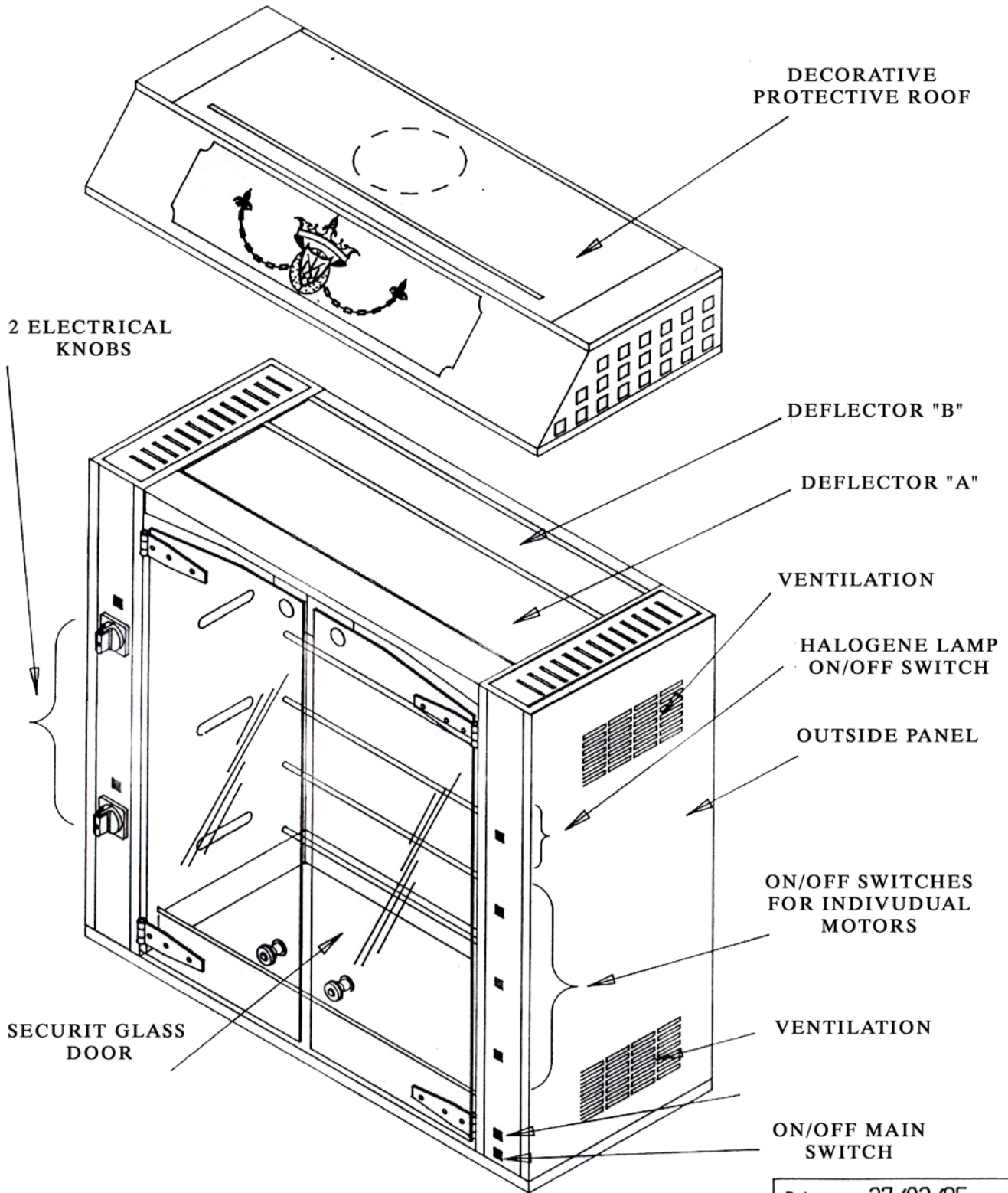

Date: 27/02/95

Numero: 3138

SPECIFICATION SHEET OF THE GRANDE FLAMME ELECTRIC



Z.I. AV DE LA TRENTAINE  
 77500 CHELLES - FRANCE  
 TEL(1):60.08.35.53 - TELEX:690258F  
 TELEFAX:64.26.16.85

**GRANDE FLAMMES ELECTRIC REF: 950/1350 - 5 SPITS**

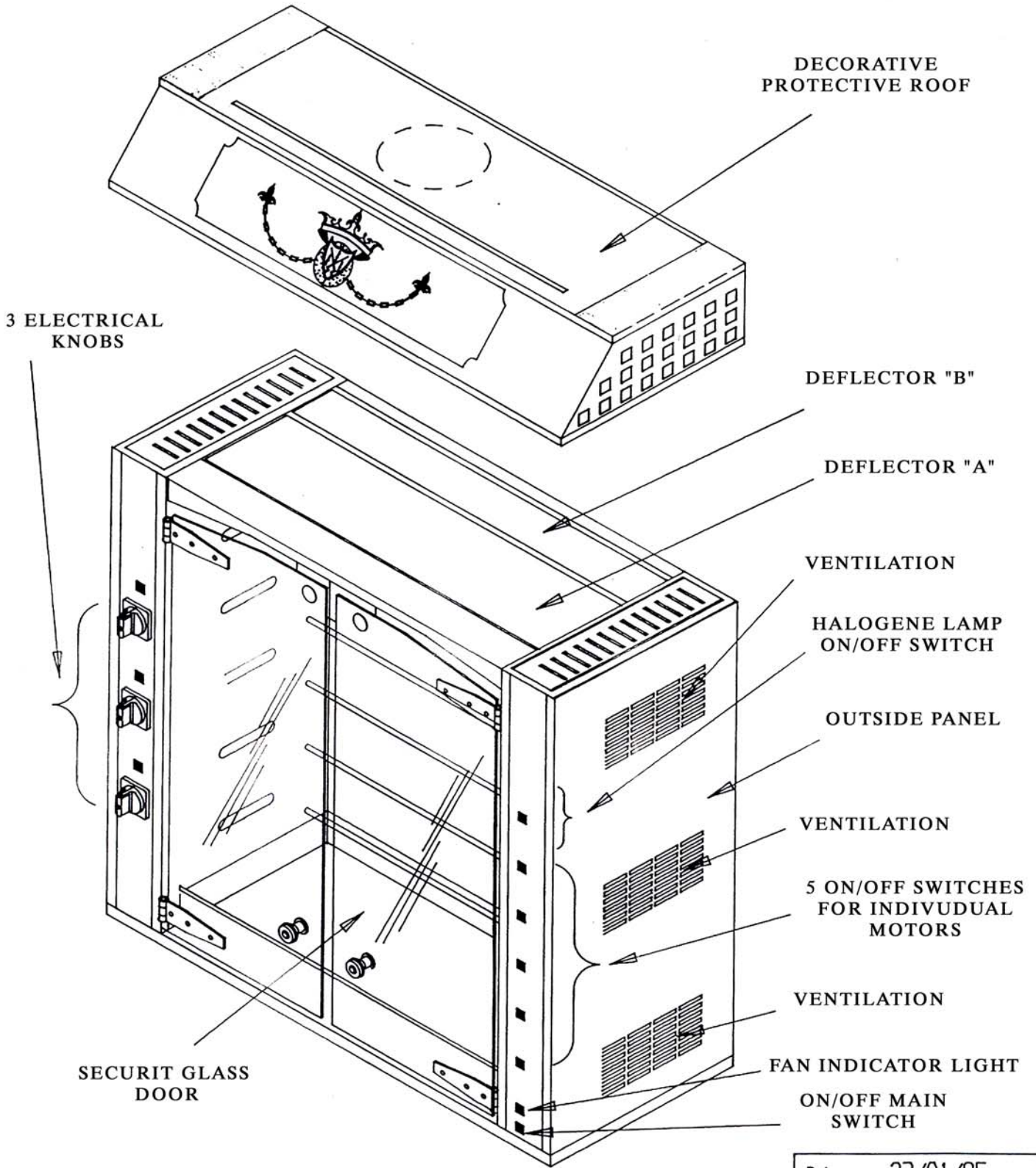

Date: 23/01/95

SPECIFICATION SHEET OF THE GRANDE FLAMME ELECTRIC

Numero: 3047

**Kotisol**

Z.I. AV DE LA TRENTAINE  
 77500 CHELLES - FRANCE  
 TEL(1):60.08.35.53 - TELEX:690258F  
 TELEFAX:64.26.16.85

**GRANDE FLAMMES ELECTRIC REF: 950/1350/1650 - 8 SPITS**

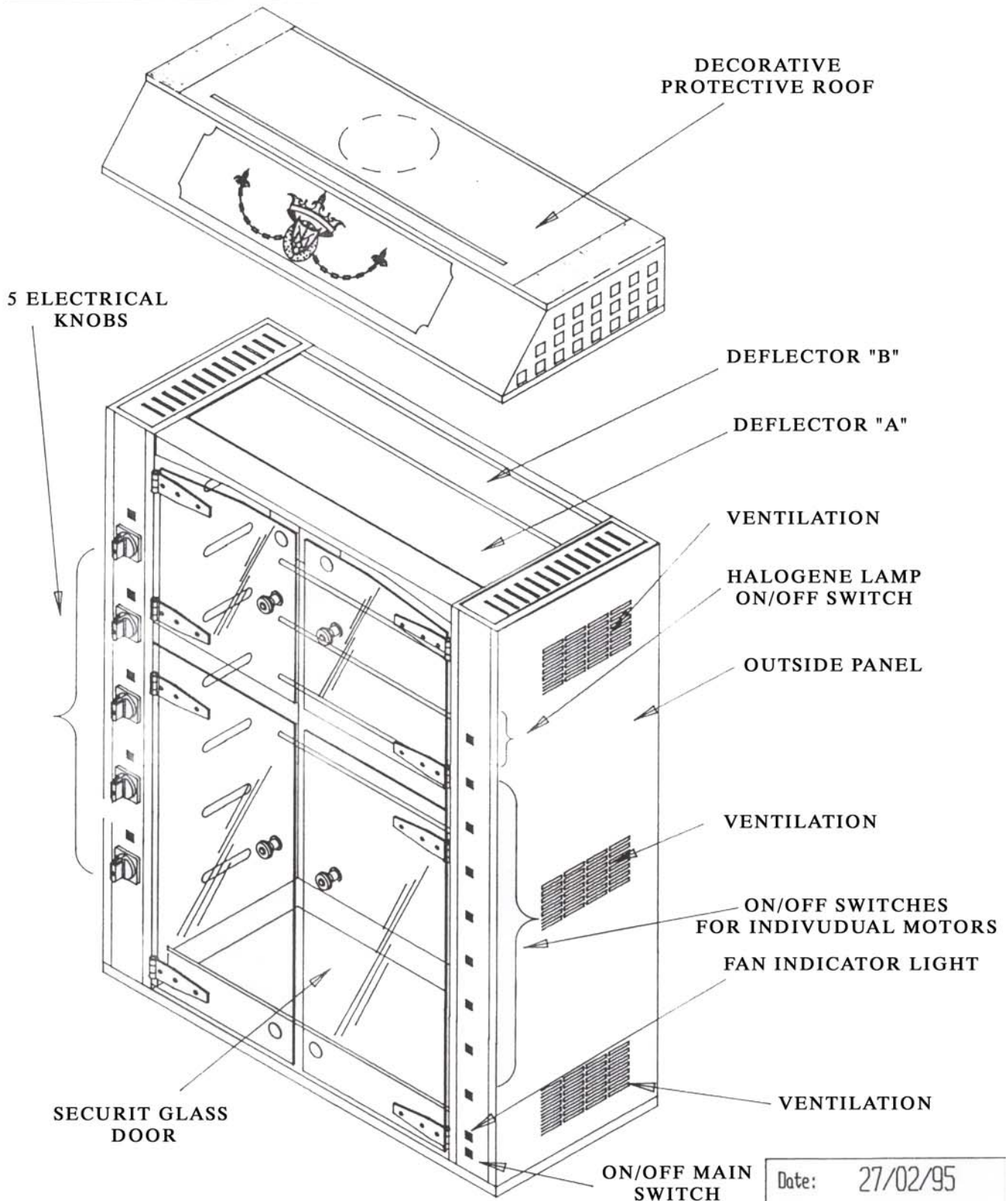

SPECIFICATION SHEET OF THE GRANDE FLAMME ELECTRIC	Date: 27/02/95
	Numero: 3139

**Rotisol**

Z.I. AV DE LA TRENTAINE  
 77500 CHELLES - FRANCE  
 TEL(1): 60.08.35.53 - TELEX: 690258F  
 TELEFAX: 64.26.16.85

# GRANDE FLAMME ELECTRIC

N° 3063

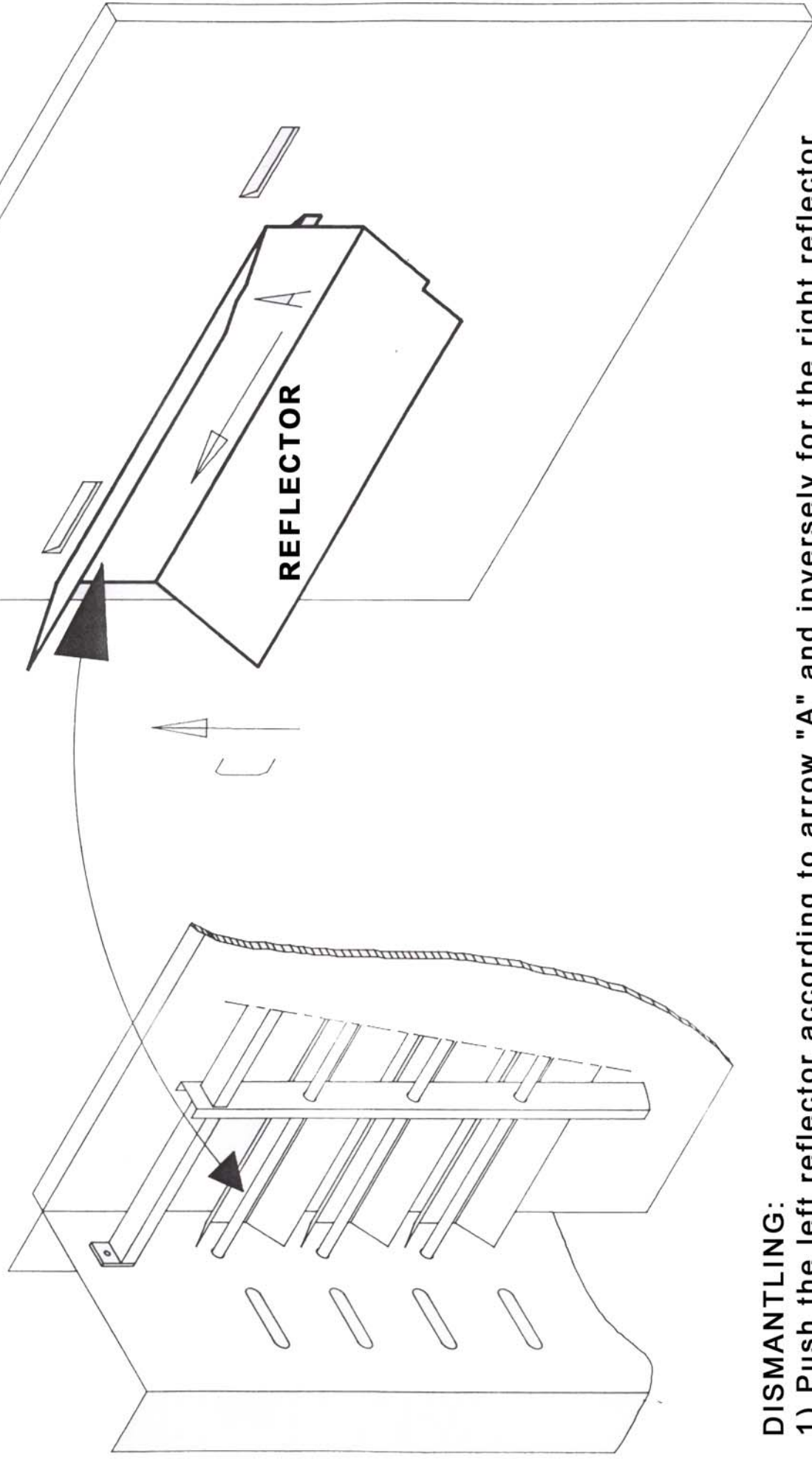

## DISMANTLING:

- 1) Push the left reflector according to arrow "A" and inversely for the right reflector
- 2) Pull the reflector towards arrow "C"

HOW TO USE THE ELECTRICAL KNOBS ?

ELECTRICAL KNOB

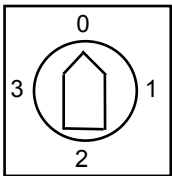

POSITION 1

ELEMENTS B ON

POSITION 2

SWITCHES OFF ELEMENTS B AND SWITCHES ON ELEMENTS A

POSITION 3

ALL 4 ELEMENTS B AND A ARE ON

TOP HEATING ELEMENT

A

B

A

B

ELECTRICAL KNOB

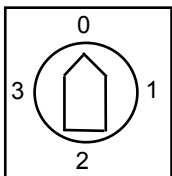

POSITION 1

ELEMENTS C ON

POSITION 2

SWITCHES OFF ELEMENTS C AND SWITCHES ON ELEMENTS D

POSITION 3

ALL 4 ELEMENTS C AND D ARE ON

MIDDLE HEATING ELEMENTS

D

C

C

D

HOW TO USE THE MOTOR SWITCHES ?

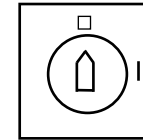

QUARTZ LAMP ON/OFF SWITCH

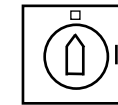
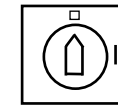
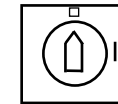

ON/OFF SWITCHES FOR 3 INDIVIDUAL MOTORS

position OFF

| position ON

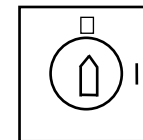

ON/OFF MAIN SWITCH

FAN INDICATOR LIGHT



If the red switch lighted = fan break down. Call then Rotisol

HOW TO USE THE ELECTRICAL KNOBS ?

ELECTRICAL KNOB

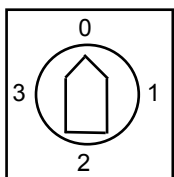

POSITION 1  
ELEMENTS A ON  
POSITION 2  
SWITCHES OFF ELEMENTS A AND  
SWITCHES ON ELEMENTS B  
POSITION 3  
ALL 5 ELEMENTS A AND B ARE ON

TOP HEATING ELEMENT

B
A
B
A
B

ELECTRICAL KNOB

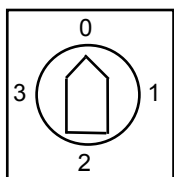

POSITION 1  
ELEMENTS C ON  
POSITION 2  
SWITCHES OFF ELEMENTS C AND  
SWITCHES ON ELEMENTS D  
POSITION 3  
ALL 4 ELEMENTS C AND D ARE ON

MIDDLE HEATING ELEMENTS

D
C
C
D

ELECTRICAL KNOB

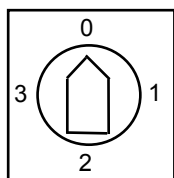

POSITION 1  
ELEMENTS E ON  
POSITION 2  
SWITCHES OFF ELEMENTS E AND  
SWITCHES ON ELEMENTS F  
POSITION 3  
ALL 4 ELEMENTS E AND F ARE ON

BOTTOM HEATING ELEMENTS

F
E
E
F

HOW TO USE THE MOTOR SWITCHES ?

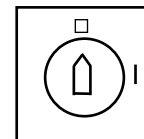

QUARTZ LAMP ON/OFF SWITCH

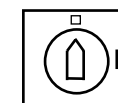
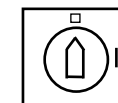
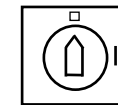
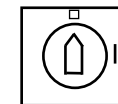
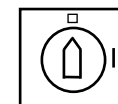

ON/OFF SWITCHES FOR 5 INDIVIDUAL MOTORS

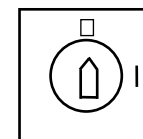
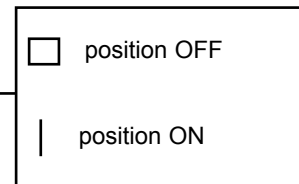

ON/OFF MAIN SWITCH

FAN INDICATOR LIGHT



If the red switch lighted = fan break down. Call then Rotisol

HOW TO USE THE ELECTRICAL KNOBS ?

HOW TO USE THE MOTOR SWITCHES ?

ELECTRICAL KNOB

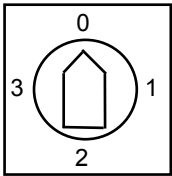

POSITION 1  
ELEMENTS A ON  
POSITION 2  
SWITCHES OFF ELEMENTS A AND  
SWITCHES ON ELEMENTS B  
POSITION 3  
ALL 5 ELEMENTS A AND B ARE ON

TOP HEATING ELEMENT

B
A
B
A
B

ELECTRICAL KNOB

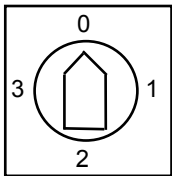

POSITION 1  
ELEMENTS C ON  
POSITION 2  
SWITCHES OFF ELEMENTS C AND  
SWITCHES ON ELEMENTS D  
POSITION 3  
ALL 4 ELEMENTS C AND D ARE ON

MIDDLE HEATING ELEMENTS

D
C
C
D

ELECTRICAL KNOB

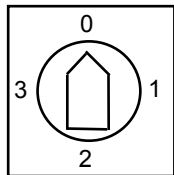

POSITION 1  
ELEMENTS E ON  
POSITION 2  
SWITCHES OFF ELEMENTS E AND  
SWITCHES ON ELEMENTS F  
POSITION 3  
ALL 5 ELEMENTS E AND F ARE ON

BOTTOM HEATING ELEMENTS

F
E
E
F
F

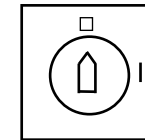

QUARTZ LAMP ON/OFF SWITCH

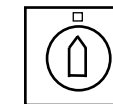
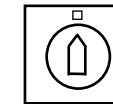
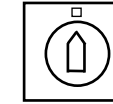
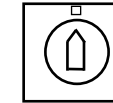
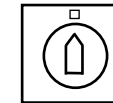

ON/OFF SWITCHES FOR 5 INDIVIDUAL MOTORS

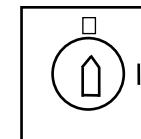
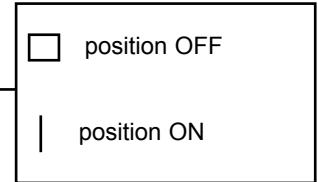

ON/OFF MAIN SWITCH

FAN INDICATOR LIGHT



If the red switch lighted = fan break down. Call then Rotisol

# GRANDE FLAMME ELECTRIC MODELS: 950/8, 1350/8, 1650/8

N 3095A

## HOW TO USE THE ELECTRICAL KNOBS ?

### ELECTRICAL KNOB

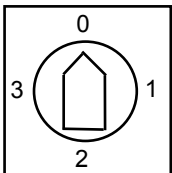

#### POSITION 1

ELEMENTS A ON

#### POSITION 2

SWITCHES OFF ELEMENTS A AND SWITCHES ON ELEMENTS B

#### POSITION 3

ALL 5 ELEMENTS A AND B ARE ON

### TOP HEATING ELEMENT

B

A

B

A

B

### ELECTRICAL KNOB

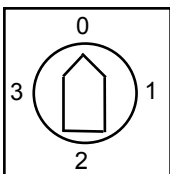

#### POSITION 1

ELEMENTS C ON

#### POSITION 2

SWITCHES OFF ELEMENTS C AND SWITCHES ON ELEMENTS D

#### POSITION 3

ALL 3 ELEMENTS C AND D ARE ON

### 3 HEATING ELEMENTS

D

C

D

### ELECTRICAL KNOB

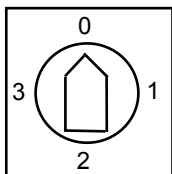

#### POSITION 1

ELEMENTS E ON

#### POSITION 2

SWITCHES OFF ELEMENTS E AND SWITCHES ON ELEMENTS F

#### POSITION 3

ALL 3 ELEMENTS E AND F ARE ON

### 3 HEATING ELEMENTS

F

E

F

### ELECTRICAL KNOB

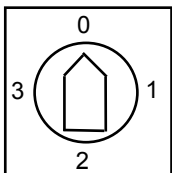

#### POSITION 1

ELEMENTS G ON

#### POSITION 2

SWITCHES OFF ELEMENTS G AND SWITCHES ON ELEMENTS H

#### POSITION 3

ALL 4 ELEMENTS G AND H ARE ON

### 4 HEATING ELEMENTS

H

G

G

H

### ELECTRICAL KNOB

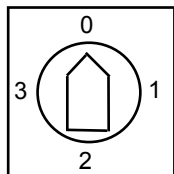

#### POSITION 1

ELEMENTS J ON

#### POSITION 2

SWITCHES OFF ELEMENTS J AND SWITCHES ON ELEMENTS I

#### POSITION 3

ALL 5 ELEMENTS J AND I ARE ON

### 5 HEATING ELEMENTS

I

J

I

J

I

# ROTISOL

## HOW TO USE THE MOTOR SWITCHES ?

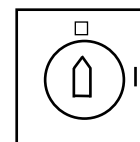

QUARTZ LAMP ON/OFF SWITCH

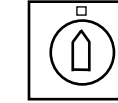
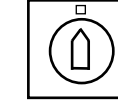
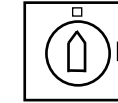
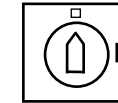
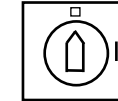
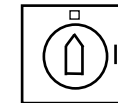
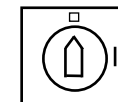
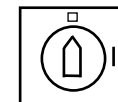

ON/OFF SWITCHES FOR 8 INDIVIDUAL MOTORS

position OFF

| position ON

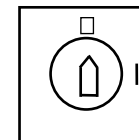

ON/OFF MAIN SWITCH

FAN INDICATOR LIGHT



If the red switch lighted = fan break down. Call then Rotisol