

Rotisol-France, Inc.

PERFORMANCE ROTISSERIES

GAS

TYPE: A

USER MANUAL

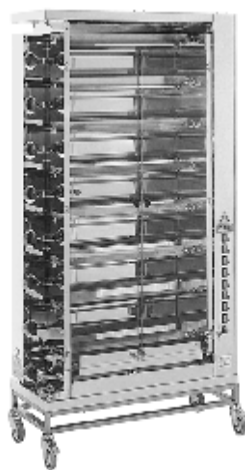

1 – GENERAL INFORMATION

2 – INITIAL OPERATION – USE

2 – 1 OPERATION INSTRUCTIONS

2 – 2 RECOMMENDATION

2 – 2 – 1 WHAT TO DO

2 – 2 – 2 WHAT NOT TO DO

2 – 3 COOKING

3 – CLEANING – MAINTENANCE

4 – EQUIPMENT VERIFICATION

1 – GENERAL INFORMATION

“Rotisol” Rotisserie, Performance line ref: PR2, PR4, PR6, PR8.

This Equipment is for professional use and should be operated by qualified personnel.

This equipment should be installed according to current regulations and standards, in a well-ventilated location.

We recommend that you use a qualified installer to install the equipment.

The rating plate is located at the back of the equipment.

2 – INITIAL OPERATION – USE

In order to avoid grease splashes and for the proper operation of the unit, the glass doors must remain closed during cooking cycles.

2 – 1 OPERATION INSTRUCTIONS

- Put about 1” of water in the drip pan

- Turn on the main switch located at the bottom on the right side of the rotisserie.

- Turn ON all the burners 15 minutes before cooking.

- Spit the products tightly on the spits and load the rotisserie. Insert the right side of the spit first in the motor shaft.

- To start rotating switch on the independent spit motors located on the right side. You have one switch per spit.

* The white light indicates when the power is ON.

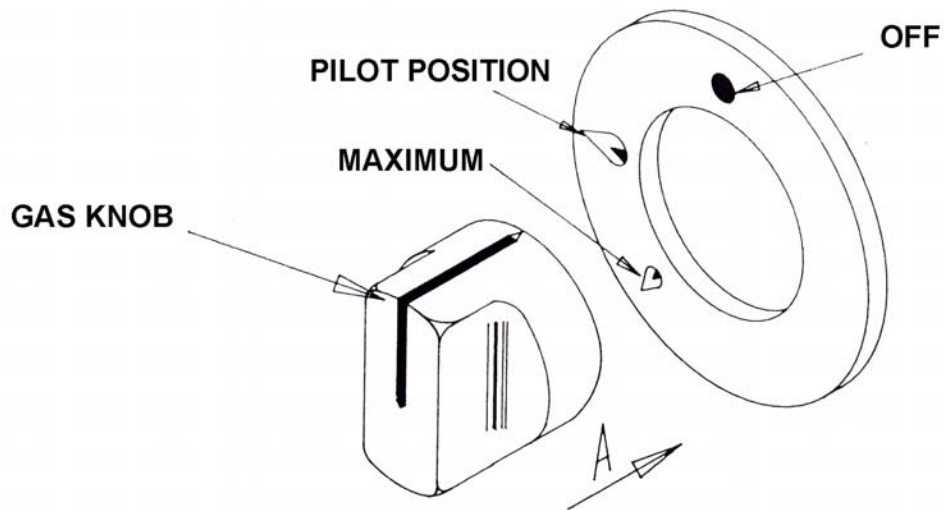

INSTRUCTION FOR USING BURNERS

PICTURE 1

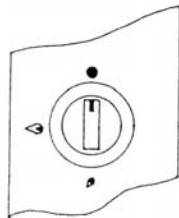

- There are 3 positions for each gas knob:
- OFF (arrow up - picture 1)
- Pilot (arrow to the left - picture 2)
- Cooking (arrow down - picture 3)

PICTURE 2

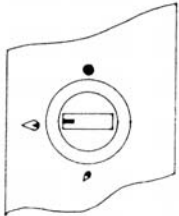

- Getting started:
- a) to turn on the gas, rotate the knob a quarter to the left (on pilot position)
- b) push on the knob and hold it pushed
- c) place a flame in front of the pilot for 15-20 seconds
- d) release the knob: the pilot should be ON

PICTURE 3

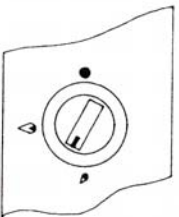

- To start cooking, rotate the knob another quarter to the left (on cooking position). You can adjust the heat by turning the knob between the pilot and the cooking positions. (that allows you to control the cooking).

2 – 2 RECOMMENDATION

2 – 2 - 1 WHAT TO DO

- You always need to fill the bottom of the drip pan with water (1/2 to 1 inch) when using the rotisserie.
- Use some heat protecting gloves to unload and load the spits.
- Clean the glass doors and the inside panels daily with a non abrasive cleaner

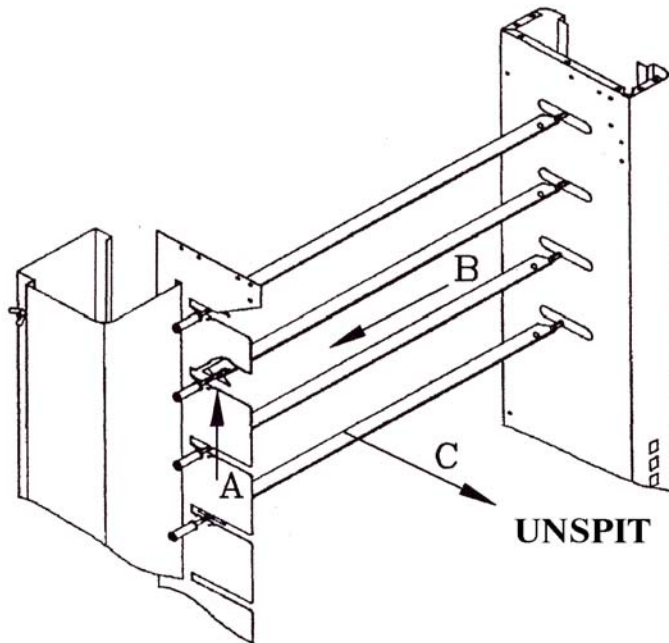

- Open the glass doors and block them
- Release the spit from its handle as indicates by arrow “A”
- Release the spit from the spit holder as indicates by arrow “B”
- Pull out the spit as indicates by arrow “C”

2 – 2 – 1 WHAT NOT TO DO

- Never leave the water and grease overdraw the drip pan. Empty it regularly.

2 – 3 COOKING

- The cooking time, for a 3 lbs bird, vary between 55 and 65 minutes (between 165F and 185F core temperature).

3 – CLEANING – MAINTENANCE

3 – 1 DAILY

- It is very important to clean your rotisserie on a daily basis. Soak the spits and the drip pan for easier cleaning.
The inside stainless steel panels as well as the glass doors must be cleaned with a non-abrasive detergent and a soft rag.

3 – 2 ONCE A MONTH

- Free the motor of grease deposits by applying a strong degreaser with a brush on the motor shafts (right side of the rotisserie). Turn the motors ON for 5 minutes and rinse with a soft sponge.

3 – 3 EVERY 6 MONTHS

- Do a thorough check up of the rotisserie.

For a better operation, we recommend to establish a maintenance program with a qualified company.

4 – EQUIPMENT VERIFICATION

We recommend checking the equipment upon reception. Your rotisserie was packaged with care. If you notice something wrong, please inform your vendor immediately.

**DESCRIPTION OF THE GAS
PERFORMANCE ROTISSERIE**

